



**Enchlor Inc.
Gas Chlorination Systems
Series 2100 High Capacity Systems**

**Enchlor Inc.
130 West Main Street
Silverdale, PA 18962**

**215-453-2533
www.enschlor.com**

Table of Contents

2. SECTION I: Safety Information (Ton Containers) 3
3. SECTION II: Design and Installation Notes 4
4. SECTION III: System Installation 5
5. SECTION IV: Chlorination System Vacuum Test 9
6. SECTION V: Start Up of Chlorination 9
7. SECTION VI: Shut Down Procedure 9
8. SECTION VII: Rate Valve Operation 9
9. SECTION VIII: Troubleshooting 10
10. APPENDIX: Repair and Preventative Maintenance 12
a. Section A-I: Servicing the Vacuum Regulator 12
b. Section A-II: Remote Meter 13
d. Section A-III: Ejector Nozzle and Throat 13
e. Section A-IV: Ejector Check Valve 14
f. Section A-V: Switchover Module 14
11. Parts Drawings 15
12. Ejector Performance Curves 18
13. System Drawings and Models..... 19

**Enchlor Inc.
130 West Main Street
Silverdale, PA 18962**

215-453-2533
www.enchlor.com

SECTION I: SAFETY INFORMATION (TON CONTAINERS)

TAKE CARE WITH CHLORINE!

1. Valve protection covers must be on ton container valves **before they are ever moved**.
2. The ton container should be levelly placed on a pair of trunnions.
3. Always place container so valves are in vertical alignment and use only the top valve (which is the gas valve).

BOTTOM VALVE IS LIQUID—DO NOT USE.

4. For best operation and safety, the ton container and vacuum regulator should be protected from the elements and direct sunlight.
5. **NEVER** apply heaters or heat lamps directly on a chlorine container.

IMPORTANT NOTE:

Whenever possible, the use of chlorine gas manifolds should be avoided. Because manifolds contain pressurized chlorine gas, they pose an increased risk of a chlorine gas leak. When the system design necessitates the use of manifolds extreme care should be taken with regards to their installation, operation and maintenance.

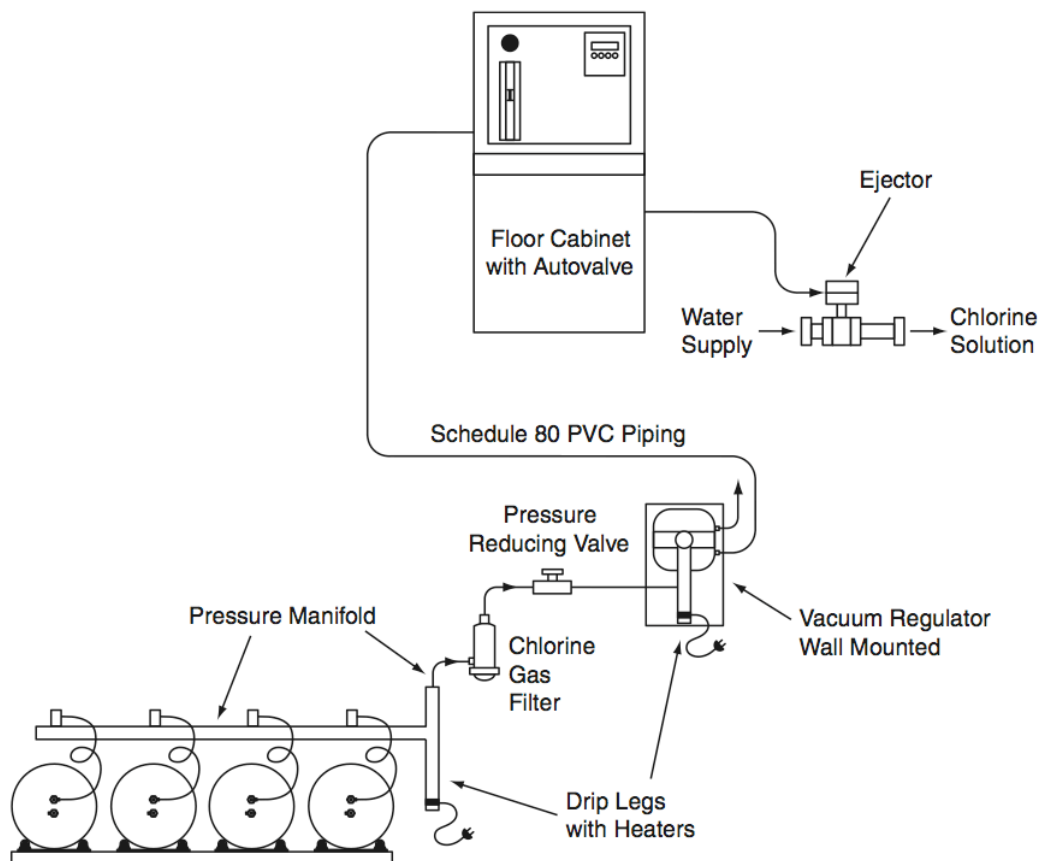

SECTION II: DESIGN AND INSTALLATION NOTES

1. The “all vacuum” system means that system will shut off at the vacuum regulator inlet valve, should the vacuum line be broken, if water is stopped for any reason, or if the vacuum regulator is physically damaged.

2. Choosing a vacuum regulator feed capacity:

VACUUM REGULATOR SIZE SHOULD BE ON MAXIMUM POSSIBLE FLOW.

Imperial Units:

$\text{GPM} \times 0.012 \times (\text{PPM}) \text{ Dosage} = \text{PPD}$

Gallons Per Minute Parts Per Million Pounds Per Day (Cl₂)

Example: $30,000 \text{ GPM} \times 0.012 \times 3 \text{ PPM} = 1080 \text{ PPD}$

In this example a 2000 PPD vacuum regulator would be adequate.

Metric Units:

$\text{LPM} \times 0.0599 \times (\text{PPM}) \text{ Dosage} = \text{GPH}$

Liters Per Minute Parts Per Million Grams Per Hour (Cl₂)

3. **TOTAL BACK PRESSURE** is the pressure in the pipeline to be chlorinated plus the friction losses in the solution line between the ejector and the point of injection at the pipeline. Ejectors capable of operating with back pressures up to 150 PSIG are available.

4. It is preferable that the ejector be located near the point of solution injection in order to eliminate the need for **solution lines**. Friction losses in the solution line will **increase the ejector back pressure**. Friction losses can be reduced by increasing the solution line internal diameter and limiting the number of flow restrictions and turns. Also, be sure that the solution line material is resistant to **the highly concentrated chlorine mixture**. **Avoid solution lines wherever possible.**

5. Schedule 80 PVC pipe is recommended to carry the chlorine under vacuum from the vacuum regulator to the ejector.

SECTION III: SYSTEM INSTALLATION

(I) INSTALLATION OF 2" FLANGED EJECTOR (Refer to Figure 1A)

1. Installation of EJE-2000-CL2 Ejectors:
 - a. The water inlet and outlet connections are 2" flanged, four bolt, 150 lb., Van Stone style in Schedule 80 PVC.
 - b. The shorter end is the water inlet (nozzle side) and the longer end is the chlorinated solution outlet.
 - c. Install both flanges carefully with new GAE-308-000 gaskets from Enchlor.
2. Testing of ejector. *(Note: The vacuum regulator should not be connected and the chlorine container valves should remain closed.)*
 - i. Piping hook up to ejector (Refer to Figure 1A):
 - a. Ejector should be installed down stream at a sufficient distance so that chlorinated water is not re-circulated through the booster pump.
 - b. On the water inlet side to the ejector nozzle the following should be installed: a water inlet valve, Y-strainer, and a pressure gauge.
 - ii. Testing for sufficient pump pressure to operate ejector. Also checking that booster pump (if applicable) operating in the proper direction.

*Note 1: Ejector must have some back pressure to prevent jetting.
(Jetting causes loss of vacuum)*

Note 2: When injecting into a contact chamber a tee should be installed on the solution line with a vacuum breaker to prevent siphoning.

- a. If operating with city water pressure (no booster pump), open the water inlet valve to the ejector and feel for suction (with your hand) at the gas intake of the ejector.
- b. If using a booster pump, open the water inlet valve to the ejector and the pressure gauge should indicate a sufficient boost. (See ejector curves at the end of this manual.) If pump is operating in proper direction there should be a strong vacuum at the gas intake of the ejector. Feel for suction (with your hand) at the gas intake of the ejector.
- c. If the ejector has tested satisfactorily continue on to the next step (Installation of Floor Cabinet and/or Vacuum Regulator).

(II) INSTALLATION OF CABINET or WALL PANEL

1. **Location:** Select a location for installation of the cabinet where it will be protected from unauthorized personnel. The location should be selected to permit easy access to both the front and rear of the cabinet for operation and maintenance procedures. The cabinet is not suitable for outdoor installation.
2. **Connections:** Schedule 80 PVC union connections are provided with all Enchlor floor cabinets for the vacuum inlet from the vacuum regulator and vacuum outlet to the ejector. The size of the union is dependant on the capacity of the floor cabinet. Refer to Table 2 for connection sizing. Threaded connections should be prepared with PTFE (Teflon) tape prior to assembly.
3. **Wiring:** For wiring installation consult the Series 1100 operation and maintenance manual.

(III) INSTALLATION OF VACUUM REGULATOR

1. **Mounting:** Install the vacuum regulator panel vertically on a wall in a location convenient to the gas manifold piping. The drip leg must extend downward.

2. **Manifolds:** A 3/4" forged steel union is provided for connection to the gas manifolds. Ensure this union is tightened evenly but not excessively after connections have been made.

3. **Vacuum Connections:** The size of the vacuum connection is determined by the capacity of the vacuum regulator. Schedule 80 PVC piping is recommended for vacuum lines of 1,000 PPD (20 kg/hr) or higher. A threaded Schedule 80 PVC union is provided with the vacuum regulators in the appropriate size. Connect vacuum outlet on vacuum regulator to either the remote meter panel bottom union, a gas inlet union on the switchover module or the gas inlet on the floor cabinet (depending on the system arrangement). *See Figures 2 and 3 for details.*

4. **Vent Tubing Connections:** All Enchlor vacuum regulators are equipped with a vent tubing connection for directing and venting chlorine gas to a safe location. Tubing is also provided. Connect the appropriate tubing (provided) to the vent connection on the vacuum regulator vent fitting. Run the vent tubing to a safe location (outside the building). Whenever possible, avoid low spots in the vent tubing and direct the tubing down from the vacuum regulator to keep moisture from accumulating or entering the vacuum regulator. Install an insect screen (provided) on the outside end of the vent tubing.

5. **Drip Leg Heater:** Prior to startup of the system or prior to placing any new ton container on suction, the drip leg heater(s) must be powered for at least 15 minutes. This will ensure proper evaporation of trapped chlorine liquid takes place.

Table 2: Vacuum line Piping

Capacity (Max) Piping Size

2,000 PPD (40 kg/hr) 1"

8,000 PPD (160 kg/hr) 1-1/2"

10,000 PPD (200 kg/hr) 2"

NOTE: Ensure threaded connections are clean and prepared with adequate PTFE (Teflon) tape or other suitable thread sealant. Do not over tighten PVC threaded connections.

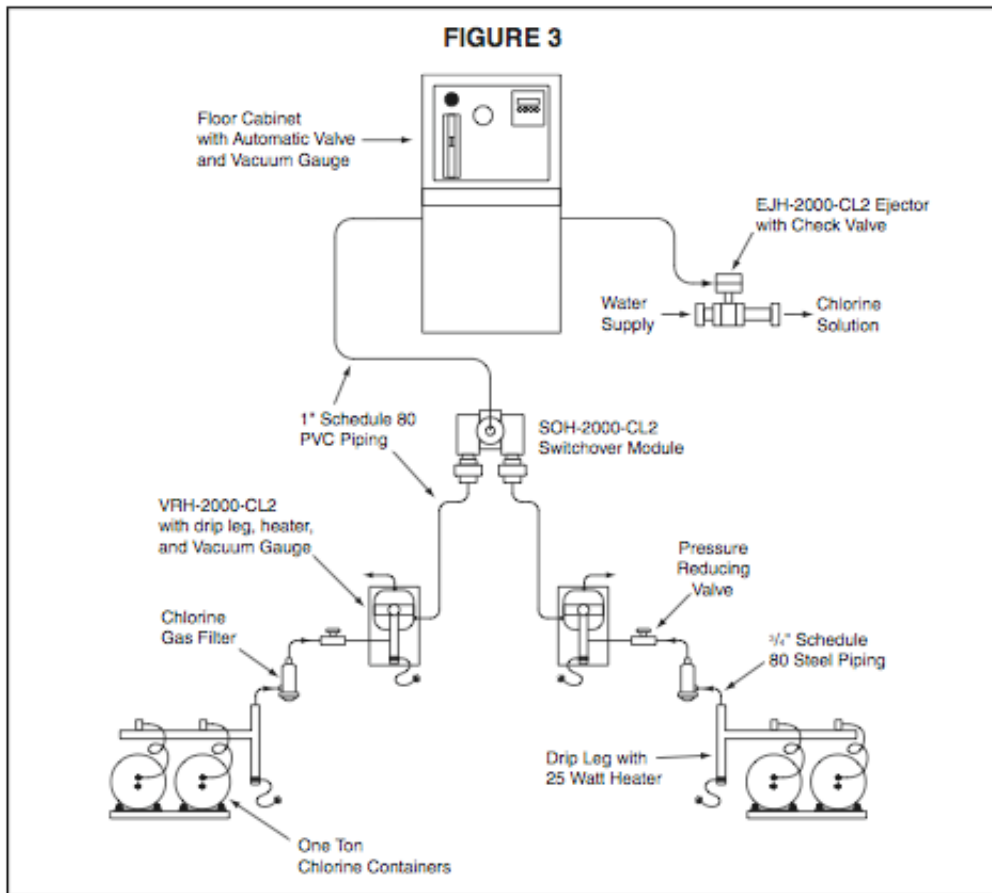
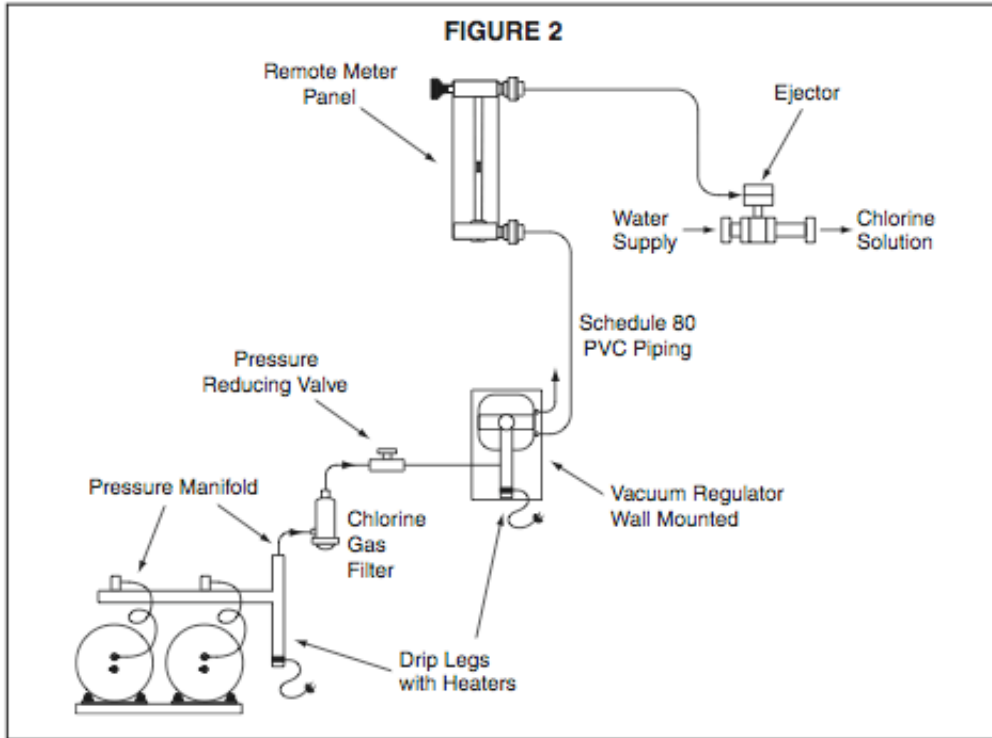

(IV) SWITCHOVER MODULES AND REMOTE METERS (Refer to Figure 3)

1. **Switchover modules:** (Gas flow is from bottom/side to top from one side only at a time)
 - a. Connect the two lines from the vacuum regulators to the side unions.
 - b. Connect the single line out to the remote meter(s) to the top union.
2. **Remote Meters:** (Gas flow is from bottom to top through the tube)
 - a. Connect the input line (from the vacuum regulator or switchover module) to the lower union.
 - b. Connect the output line (to the ejector) to the upper union.

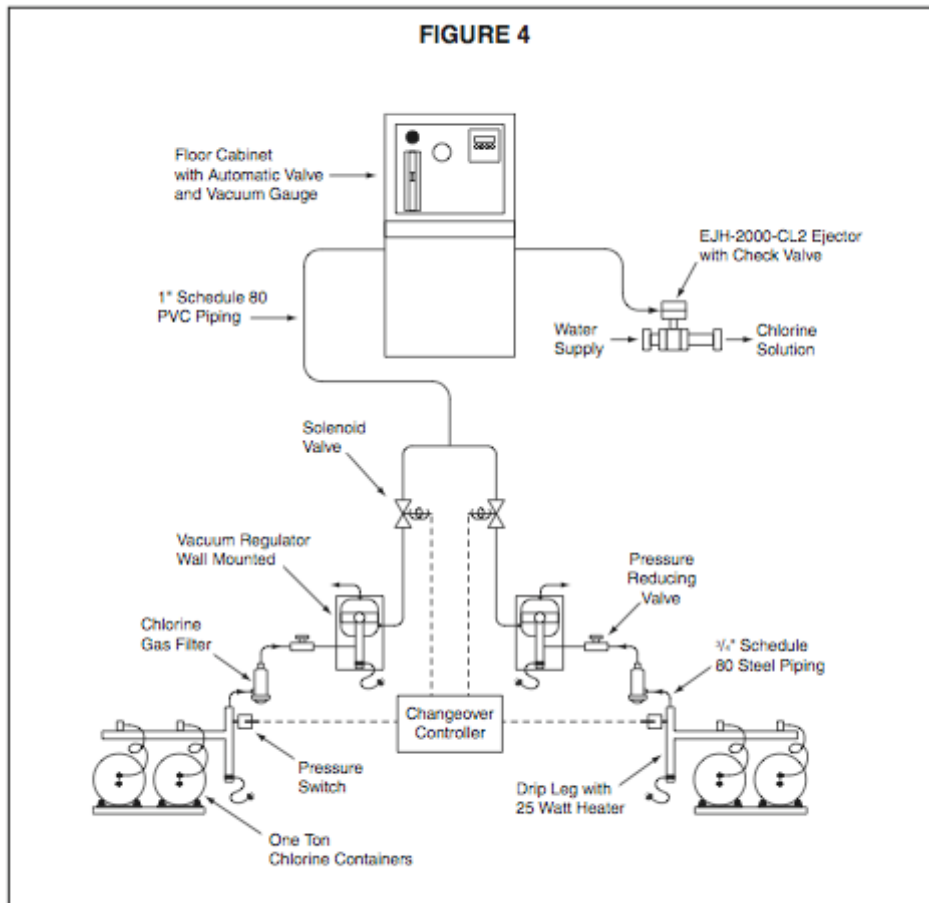

Figure 4: Electronic changeover system. Pressure switches indicate when the pressure falls in the supply containers in use indicating that they are empty. Then the controller closes the valve in the vacuum line for that set of containers and opens the other valve. Before removing the empty containers, the container valves should be closed and the solenoid opened to allow the full evacuation of the depleted manifold.

(V) REMOTE METER INSTALLATION

1. The float may be shipped outside the tube to prevent damage.
2. Install the float per the parts drawing and the feed rate reading drawings.
(See page 20 for float orientation.)

SECTION IV: CHLORINATION SYSTEM VACUUM TEST

1. **Do Not** open chlorine container valve until vacuum test is satisfactorily completed.
 - a. Vacuum Test
With the chlorine container(s) still closed, start the ejector booster pump and the meter tube float should drop to the bottom within about ten seconds. If the float continues to bounce there is a leak. At this time the rate valve on the remote meter should be open two or three turns. If a leak is indicated, inspect all piping connections and gaskets.
 - b. Turn off water supply to ejector.
 - c. Wait 10 minutes with water supply off. The vacuum gauge should maintain the indicated vacuum.
 - d. If the system is vacuum tight proceed to the next step.
 - e. Disconnect a union in the vacuum line to allow air to enter the system. Reconnect union.

SECTION V: START UP OF CHLORINATION

Material necessary: A small plastic squeeze bottle (provided), 1/3 full of household ammonia, for detecting chlorine leaks. When ammonia fumes contact chlorine gas a visible white smoke-like gas is produced.

(Wipe up any splashed liquid ammonia.)

1. Open chlorine container valves 1/4 turn and **close immediately**.
2. Squeeze ammonia bottle (ammonia fumes, not liquid) at all pressurized areas. If no fumes appear the seals are tight and it is OK to proceed to the next step. *(NOTE: The fumes are best observed against a dark background.)*
3. Open chlorine container valve(s) 1 turn, leave open, and **recheck for chlorine leaks**. (1 turn open of the container valve is all that's required. In an emergency you can shut it off quickly and safely. The wrench should always remain on the container valve while container valve is open.)
4. Turn remote meter rate valve knob to the right (clockwise) until shut (for startup). This will prevent the float from "jumping" during startup.
5. Turn on water supply or booster pump to ejector and set rate valve to desired flow rate. Refer to page 20 for the proper float reading edge.
6. Rate valve is not a shut off valve: it is a flow rate control only. **To shut off chlorine feed close the chlorine container valves.**
7. For Autovalve refer to Series 1100 O&M Manual.

SECTION VI: SHUT DOWN PROCEDURE

1. Close the chlorine container valves while the water supply to the ejector is still on.
2. Wait for the float to rest at bottom of meter tube.
3. Break vacuum by loosening a union (preferably nearest the vacuum regulator) in the vacuum line and retighten. (Repeat at least 2 times for more complete removal of gas from the system.)
4. Shut down the water supply to the ejector.

This procedure of shut down must be followed before a vacuum regulator is removed from a cylinder.

SECTION VII: RATE VALVE OPERATION

PREVENTATIVE MAINTENANCE NOTE: Rate valves that are not exercised frequently may experience a build up of a white powdery substance which precipitates out of the chlorine gas. In order to avoid this build up, which can cause the rate valve to become stuck in place, it is recommended that the rate valve be periodically exercised. See Appendix for rate valve maintenance instructions.

MANUAL OPERATION OF SYSTEM WITH Series 1100

Two true union ball valves are used to isolate the Series 1100 automatic control valve for manual feed rate control when maintenance or repair is necessary. These valves are accessible from the rear of the floor cabinet.

SECTION VIII: TROUBLESHOOTING

(I) PRESSURIZED LEAKS

1. Pressurized chlorine leaks are a safety hazard to life and equipment and should be corrected immediately. When searching for this type of leak there are basic safety rules to follow.
 - a. Air breathing pack should be readily available and personnel should know how to use it properly.
 - b. Exhaust fan switch should be located near outside entrance with an additional alternate outside switch appropriately located.
 - c. Chlorine valve wrenches should remain on the container valves whenever they are open.
 - d. Plastic squeeze bottle $\frac{1}{3}$ full of household ammonia.
 - e. Buddy system used (two people capable of operating system).
2. If a leak is detected the following should be checked first:
 - a. The **lead gasket** on the vacuum regulator inlet assembly.
 - i. Tighten the hex filter cap..
 - b. **Chlorine container valve packing.**
 - i. Tighten the container valve with care, not excessively! Close the valve if problem persists and notify your chlorine supplier.
 - ii. If valve is the problem try to move container with a high degree of safety to an outside location. (**Never** attempt to place container in water as this will only increase the leak and the container may float to the surface.)
 - c. Chlorine leaking out the vent due to **the inlet safety shut off valve** having dirt or damage on the valve seat.
 - i. Close the **chlorine container valve**.
 - ii. Wait until the metering float drops to zero on the flow tube.
 - iii. Turn off water supply to ejector.
 - iv. Now remove the vacuum regulator.
 - v. See Appendix for inlet safety shut off valve servicing instructions.
 - vi. After servicing & remounting vacuum regulator with a new lead gasket, pull a vacuum test **before** you turn on the chlorine container valve. **See “Chlorination System Vacuum Test” (Section IV).**

(II) NO CHLORINE FEED

Possible causes:

1. No vacuum being produced by ejector.
 - a. Disconnect piping at the ejector intake and place your hand on it; you should feel a suction.
 - b. If you feel no suction (vacuum) check in this order:
 - i. **Nozzle (See Appendix):** Turn off water supply and remove nozzle from ejector.
 - (1) It may be clogged with a stone or other foreign matter. Flush out or run pipe cleaner through only.
 - (2) If there is a build-up of rust, iron, or manganese, place the nozzle in a Muriatic acid for five minutes and rinse with water. If you see any buildup inside, you may find it necessary to clean the nozzle on a preventative maintenance schedule.
 - ii. **Inlet Water Supply.**
 - iii. Reduced city water pressure.
 - iv. Y strainer needs cleaning.
 - v. Booster pump cavitating (lost its prime).
 - vi. Booster pump insufficient boost due to wear or single phasing due to loss of one leg of power.
2. Chlorine flow blocked at vacuum regulator inlet assembly.
 - a. The **chlorine gas filter could be clogged.**
3. **Out of chlorine.**
 - a. The scale would read 2000 lbs. (1000 kg) lighter than when container was new.
 - b. Meter tube float would be at zero.

(III) CHECK VALVE FAILURE (Water in flow tube and vacuum lines)

1. Cause – Ejector check valve failure. Possible causes of ejector check valve failure:
 - a. Objects or material preventing closure of ejector check valve.
 - b. Failure of ORE-VIT-214 O-ring.
 - c. Failure of DIE-116-000 Diaphragm.
2. Corrective Action
 - a. Follow Section A-IV to repair ejector check valve.
 - b. Disassemble and dry vacuum regulator(s), remote meter(s), and switchover module.
 - c. Follow Section IV vacuum test procedure before resuming chlorination.

APPENDIX: REPAIR & PREVENTATIVE MAINTENANCE

Enchlor Inc. vacuum regulators require little service when operated according to instructions. The following are recommended maintenance instructions.

NOTE: All Enchlor systems come with a three year limited warranty. Enchlor does repair and refurbish used units at the factory. The repaired and retested units are shipped within 48 hours of arrival at the factory with a one year warranty.

Guidelines for Preventative Maintenance: See below for detailed instructions.

1. Service Rate Valves every 4 months. (See Section A-II)
2. Replace Rate Valve O-ring every 12 months. (See Section A-II)
3. Service Flow Meter every 12 months. (See Section A-II)
4. Service Ejector every 12 months. (See Sections A-III and A-IV)
5. Inspect and clean vacuum piping every 12-18 months. Replace as needed.
6. Thoroughly inspect and clean chlorine gas pressure manifold piping every 12 months. Replace any corroded or damaged parts as needed.

CAUTION: Use all recommended precautions when using chemicals of any kind, including goggles, gloves, face shields, etc.

After any of the listed repair procedures, it is necessary to go through the Start-Up (including vacuum test) again!

SECTION A-I: SERVICING THE VACUUM REGULATOR

1. **Inlet Filter:** The inlet filter consists of a filter screen (VRE-133-000) located under the hexagonal filter cap (VRE-229-000) in the inlet assembly. This cap is sealed to the inlet assembly by means of a lead inlet gasket (GAE-LED-124).

- a. Remove the filter cap and pull the inlet filter out of the assembly.
- b. Clean the screen by submerging and agitating in hot soapy water.
- c. Dry the screen thoroughly with compressed air prior to reassembly.
- d. The lead inlet gasket should be replaced whenever servicing or replacing the inlet filter screen.
- e. Tighten the filter cap to seal the lead gasket. Test carefully to ensure there is no leak before resuming operation.

2. **Venting Gas:** Venting gas is caused by the inlet safety valve failing to completely isolate the pressurized chlorine gas during stand-by operation. It is indicated by chlorine gas leaking from the end of the vent tubing. This can occur in a switchover system to the unit not on suction or in a single-regulator layout when the system is idle. The inlet safety valve can leak because of debris or buildup on the stem or seat preventing the valve from fully shutting or by damage to the stem or seat caused by passing debris. Maintaining gas filters is the best way to prevent venting.

3. **Servicing the Inlet Safety Valve:** To repair a venting vacuum regulator, it is necessary to disassemble the inlet capsule, clean the Valve Plug (VRE-141-000) and replace the inlet seat and adapter (VRE-182-000). O-rings should be replaced whenever maintenance is performed on the inlet capsule.

- a. To service the inlet safety valve, remove the inlet assembly (VRH-141-000) from the vacuum regulator back plate by unscrewing the four hex bolts (BTE-STA-139). This will expose the inlet capsule.
- b. Once the inlet capsule has been removed, carefully disassemble by unscrewing the Valve Plug (VRE-141-000) from the vent screw (VRE-182-000). This will require two flathead screwdrivers. Take care when disassembling, as the inlet capsule is spring-loaded.
- c. Replace the inlet seat and adapter (VRE-182-000), o-rings and clean the inlet plug prior to reassembly.

See drawing on page 14.

4. Inspection of the Inlet Assembly and Drip Leg: As with pressurized manifolds, it is necessary to periodically inspect the drip leg and inlet assembly for corrosion and damage. Because these parts contain pressurized chlorine gas, extreme care should be taken with regards to their maintenance.

The interior surfaces of the inlet assembly (VRE-141-000) should be carefully inspected whenever the inlet capsule is serviced. If wear or corrosion is found, this part should be replaced.

If a leak is found on the drip leg piping, the piping should be disassembled, cleaned and inspected. If wear or corrosion is found, the damaged part should be replaced. Extreme care should be taken when assembling threaded piping connections.

NOTE: After performing any maintenance on pressurized piping connections, a pressure test should be conducted with air prior to reinstalling in the chlorine gas system.

SECTION A-II: REMOTE METER

NOTE: Carefully follow shutdown procedures before performing this repair.

1. Rate Valve

- a. Fully unscrew and remove the rate valve from the meter assembly.
- b. Inspect and clean the two ORE-VIT-112 O-Rings and replace them if necessary.
- c. Clean out any visible debris or corrosion found in the meter or on the rate valve.

2. Meter Tube Assembly

- a. Carefully remove the protective covers.
- b. While carefully preventing the flow tube from falling, unscrew the meter inlet plug to allow the meter tube to be removed. This will require a 1" wrench or socket.
- c. Inspect and clean the top and bottom gaskets. Replace them if necessary.
- d. Clean the tube, float and stops carefully before reassembly.

SECTION A-III: EJECTOR NOZZLE AND THROAT

NOTE: Carefully follow shutdown procedures before performing this repair.

1. Be sure to isolate the ejector on both intake and outlet sides to prevent leakage of water or gases.
2. Disconnect the vacuum intake connection.
3. Disassemble both the intake and outlet water connection flanges and remove it from the water pipeline.
4. Remove the flanges from the Ejector Body EJE-169-000.
5. Unthread the nozzle and throat from the Ejector Body.
6. Slide the nozzle and throat out of their respective housings. Take care not to damage the threaded portion.
7. Inspect and clean the nozzle and throat interior. Soaking in Muriatic Acid is recommended if scale build-up is present. Replace them if necessary.

SECTION a-IV: EJECTOR CHECK VALVE

NOTE: Carefully follow shutdown procedures before performing this repair.

1. Remove the four bolts holding the two Check Valve Body parts together.
2. Lift the Check Valve Top Body away from the Check Valve Bottom Body.
3. The ORE-CEM-214 O-Ring should be replaced. When installing a new ORE-CEM-214, carefully ensure it is evenly seated in the groove. Lubricating the new ORE-CEM-214 O-Ring with Fluorolube is recommended.
4. Inspect the DIE-116-000 Diaphragm for damage (holes, cracking, etc.). If necessary, unscrew the diaphragm nut and bolt, preferably using a Spanner wrench and tongue and groove pliers. Use care not to snap the nut. The DIE-116-000 should be replaced every 12 to 24 months.
5. Replace the spring only if it is damaged.
6. Replace any parts necessary and reassemble.

SECTION A-V: SWITCHOVER MODULE

NOTE: Carefully follow shutdown procedures before performing this repair.

1. Disconnect all three vacuum connections and remove the switchover module.
2. Unscrew the BTE-STA-125 screws that hold the Body Flanges to the Center Body.
3. Inspect and clean the DIE-116-000 Diaphragms. If any imperfections are found or if these have been in place for 12 months or longer, they should be replaced.
4. Inspect and clean the ORE-VIT-217 O-Rings. Replace if necessary.
5. Remove and clean out any debris or corrosion.
6. Manually check to ensure that the mechanism can be switched in both directions without excessive force and without binding.



ENCHLOR^{INC}

VACUUM REGULATOR
2000ppd (40 kg/h) max
PART# VRE-2000-CL2

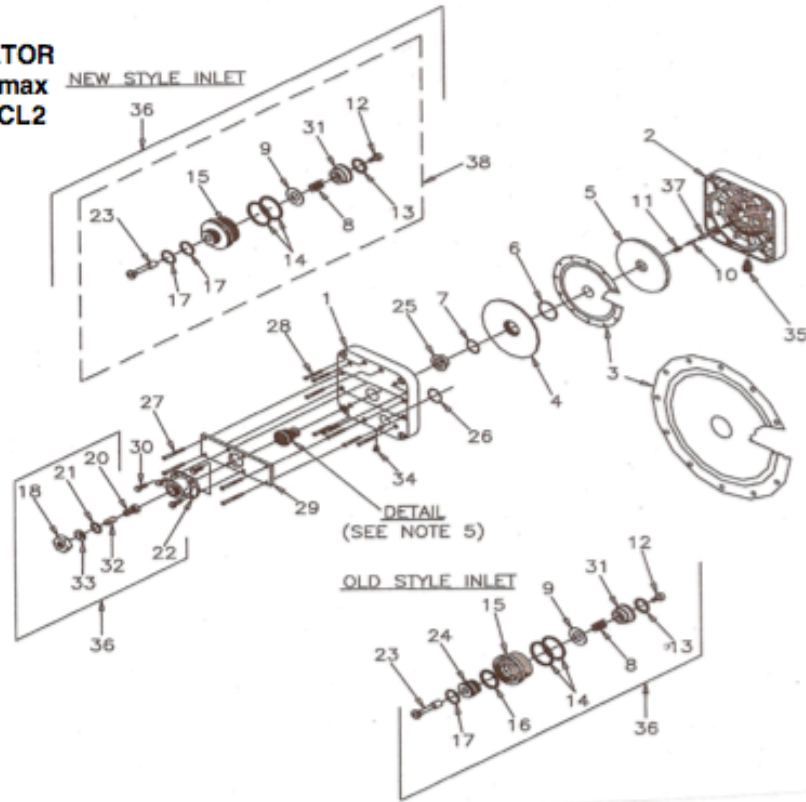

KEY #	PART#	DESCRIPTION	KEY #	PART#	DESCRIPTION
1	VRE-391-000	back body	20	VRE-547-000	filter holder
2	VRE-371-000	front body	21	GAE-LED-124	inlet gasket
3	DIE-110-000	diaphragm	22	VRE-186-000	inlet assembly
4	VRE-764-000	diaphragm back plate	23	VRE-141-000	valve plug
5	VRE-765-000	diaphragm front plate	24	VRE-543-000	valve seat
6	ORE-VIT-141	o-ring	25	VRE-335-000	diaphragm bolt
7	ORE-VIT-129	o-ring	26	ORE-VIT-225	o-ring
8	SPE-109-000	spring	27	BTE-STA-125	1/4-20 x 2 3/4" screw
9	VRE-181-000	spring retainer	28	BTE-STA-129	1/4-20 x 2 1/4" screw
10	VRE-140-000	guide pin	29	VRE-231-000	body plate
11	SPE-100-000	spring	30	BTE-STA-130	3/8-16 x 1" screw
12	VRE-182-000	vent screw	31	VRE-544-000	vent plug
13	ORE-VIT-210	o-ring	32	VRE-133-000	filter screen
14	ORE-VIT-220	o-ring	33	VRE-230-000	filter plug
15	VRE-545-000	adaptor	34	1/4" plug	1/4" plug
16	ORE-VIT-214	o-ring	35	TCE-106-200	1/2" tubing connector
17	ORE-VIT-116	o-ring	36	Inlet Assembly	Inlet Assembly
18	VRE-229-000	filter cap	37	pin guid	pin guide
19	VRE-187-000	inlet filter assembly	38	inlet capsule	inlet capsule assem
		• included in spare parts kit			

130 West Main Street, PO Box 99, Silverdale, PA 18962 USA
 PHONE: 215-453-2533 FAX: 215-453-1101 EMAIL: sales@enchlor.com WEB: www.enchlor.com

Inlet Capsule
Assembly
VRH-5919-000

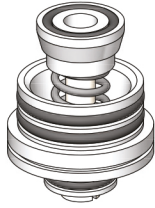

Requires this
matching part:
Diaphragm Bolt
VRH-335-000

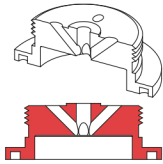

Inlet Capsule
Assembly
VRH-5919-000-1

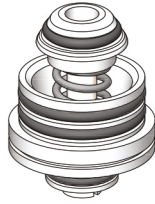

Requires this
matching part:
Diaphragm Bolt
VRH-335-000-1

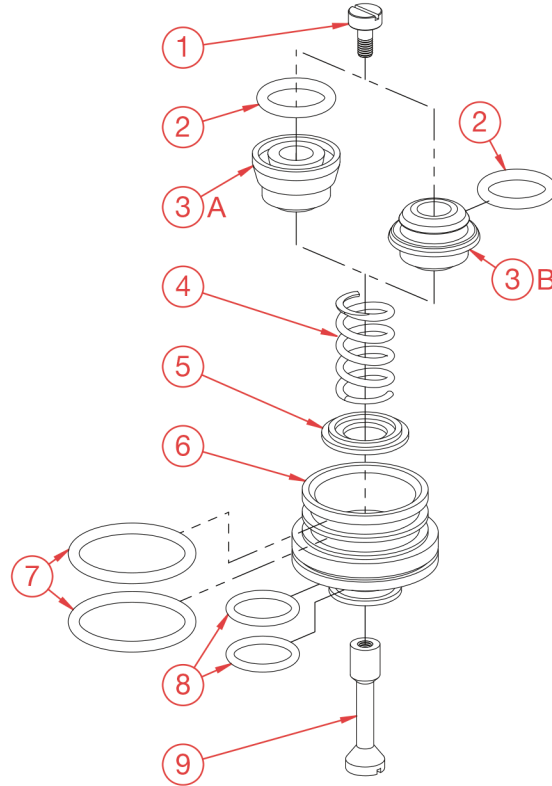
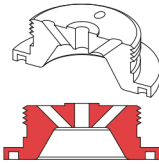

Item No.	Description	Quantity	Part No.
1	Vent Screw (Silver)	1	VRH-182-000
2	^{PM} O-Ring	1	OH-VIT-209
3A	Vent Plug (included in VRH-5919-000)	1	VRH-2318-000
3B	Vent Plug (included in VRH-5919-000-1)	1	VRH-2318-000-1
4	Spring (Tantalum)	1	SPH-109-000
5	Spring Retainer (Hastelloy)	1	VRH-181-000
6	^{PM} Seat and Adapter	1	VRH-15082-000
7	^{PM} O-Ring	2	OH-VIT-220
8	^{PM} O-Ring	2	OH-VIT-116
9	Valve Stem (Silver)	1	VRH-141-000
^{PM}	Part & Maintenance Kit	1	Refer to table below

PM components included with other parts in the following PM Kits:

Vacuum Regulator	PM Kit No.
VRH-2000-CL2	KTH-2000-VRW
VRH-8000-CL2	KTH-8000-VRW
VRH-10000-CL2	KTH-10000-VRW
WR-10000-CL2	KTH-10000-WR



INLET CAPSULE ASSEMBLY

Date: 2022-12-02-v1
EXPLODED VIEW & BOM
VRH-5919-000
and VRH-5919-000-1

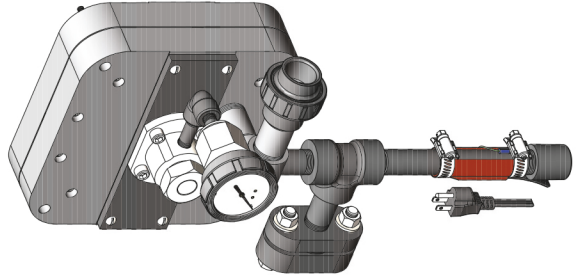
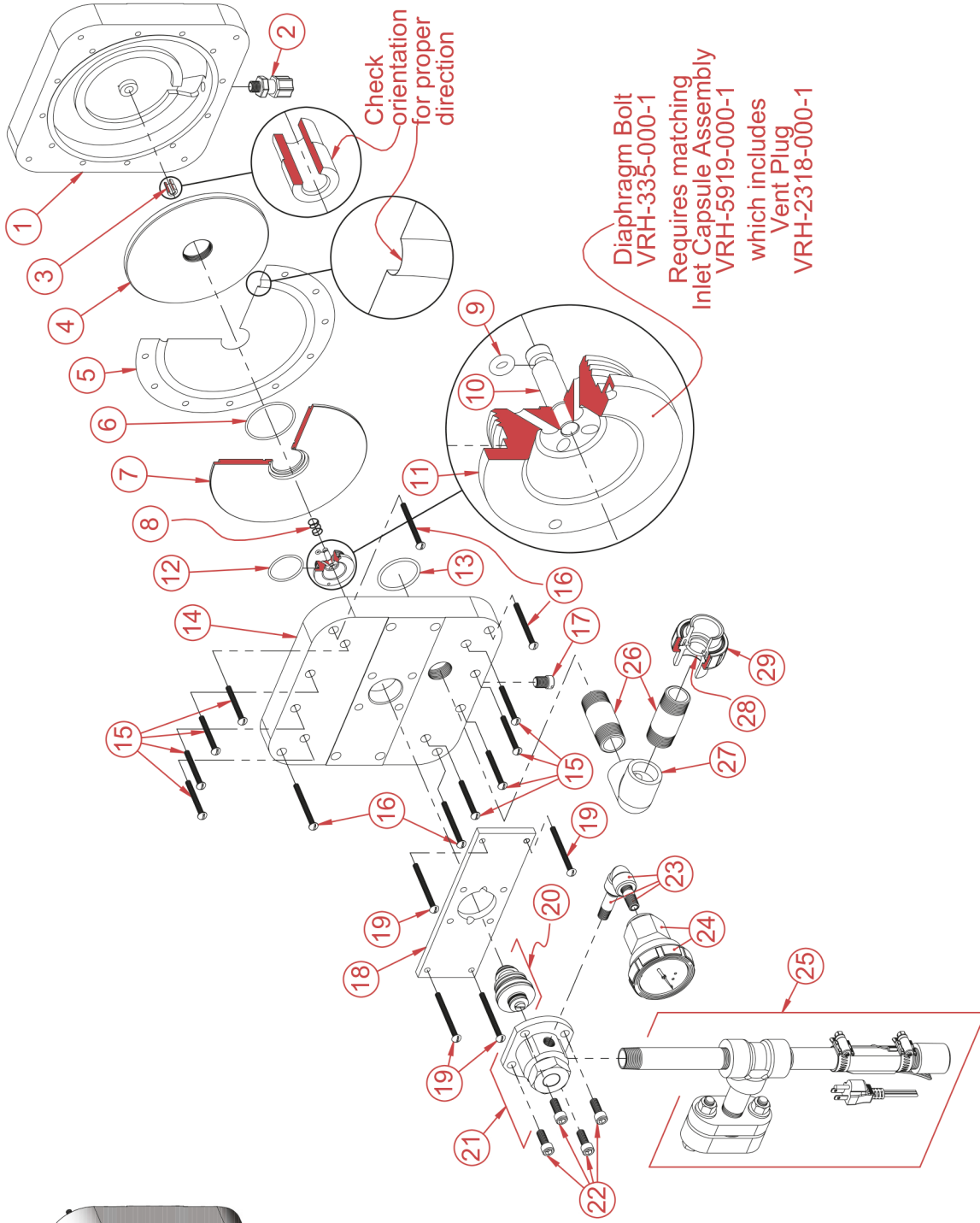

LEFT INLET
(Default Option)

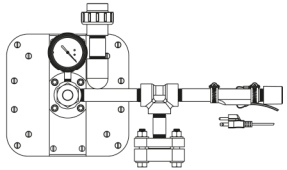

RIGHT INLET
(If Requested)

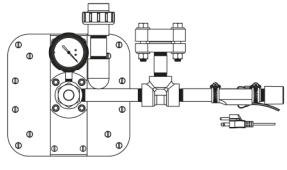

ENCHLÖR

VACUUM REGULATOR
CAPACITY 2000 - 3000 PPD (40 - 60 kg/hr)

EXPLODED VIEW
Dwg. No. VRH-2000-CL2, EXP

Item No.	Description	Quantity	Part No.	Item No.	Description	Quantity	Part No.
1	Front Body	1	VRH-12704-000	21	* Inlet Adapter Assembly	1	*VRH-5968-000
2	^{PM} 1/4" NPT 1/2" Tube Tubing Connector	1	BKF-84	22	3/8-16 x 1" Socket Head Cap Screw	4	BTH-STA-139
3	‡ Pin Guide	1	VRH-12664-001	23	Gauge Tube Assembly	1	VRH-1150-000
4	Diaphragm Front Plate	1	VRH-333-000		Nipple, 1/4" x 2" (Carbon Steel)		
5	Set of Two Diaphragms	1	DIH-110-000		Nipple, 1/4" x 1 1/2" (Carbon Steel)		
					Elbow, 1/4" (Carbon Steel)		
6	^{PM} O-Ring	1	OH-VIT-141	24	Diaphragm Protected Pressure Gauge Assembly	1	PVR-300-EW
7	Diaphragm Back Plate	1	VRH-764-000				
8	Relief Spring	1	SPH-100-000	25	* Inlet Drip Leg and Union Assembly	1	*VRH-1091-000
9	^{PM} O-Ring	1	OH-VIT-006	26	1" NPT 3" PVC Nipple	2	RH-306-000
10	Guide Pin	1	DM-201	27	1" NPT 90° PVC Elbow	1	
11	Diaphragm Bolt	1	VRH-335-000-1	28	^{PM} O-Ring (for 1" PVC Union)	1	OH-VIT-215
12	^{PM} O-Ring	1	OH-VIT-128	29	1" PVC Union Assembly	1	U-4475
13	^{PM} O-Ring	1	OH-VIT-224				
14	Back Body	1	VRH-311-000	^{PM}	Part & Maintenance Kit	1	KTH-2000-VRW
15	1/4-20 x 2 1/4" RHMS (Monel)	8	BTH-STA-129	*	See separate drawings for Exploded View and BOM		
16	1/4-20 x 2 3/4" RHMS (Monel)	4	BTH-STA-125	‡	VRH-12664-001 must be installed in the correct orientation. Smaller outside diameter into the front body first. Incorrect installation could cause venting.		
17	1/4" NPT Plug	1	PLH-108-250				
18	Back Plate	1	VRH-1397-000				
19	1/4-20 x 3" RHMS (Monel)	4	BTH-STA-279				
20	* Inlet Capsule Assembly	1	*VRH-5919-000-1				



VACUUM REGULATOR
CAPACITY 2000 - 3000 PPD (40 - 60 kg/hr)

Date: 2022-12-02-v1
BILL OF MATERIALS
Dwg. No. VRH-2000-CL2, BOM



ENCHLOR^{INC}

METER PANEL ASSEMBLY - 2000ppd (40 kg/h) max
PART# RMP-2000-CL2

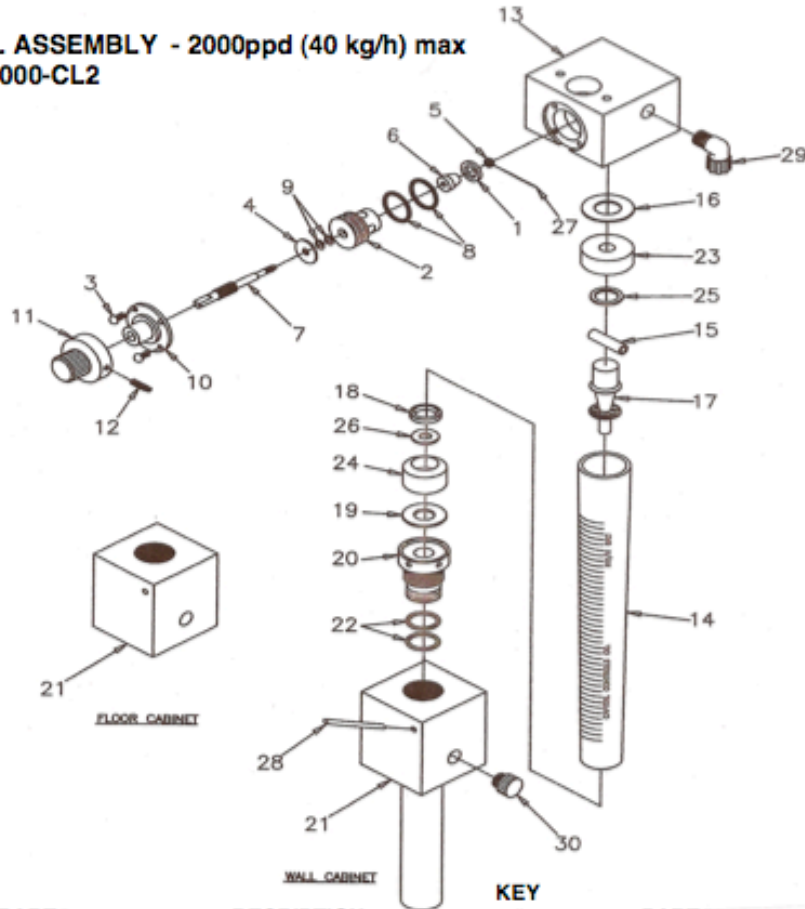

KEY #	PART#	DESCRIPTION	KEY #	PART#	DESCRIPTION
1	RVE-134-000	valve seat	15	CF	top float stop
2	RVE-345-000	valve sleeve	16	* GAE-VIT-127	top meter gasket
3	BTA-STA-122	10-24 x 3/8 screw	17	CF	meter float
4	RVE-138-000	O-ring retainer	18	CF	bottom float stop
5	RVE-137-000	retaining nut	19	* GAE-VIT-128	bottom meter gasket
6	RVE-135-000	valve plug	20	MIE-340-000	meter inlet plug
7	RVE-736-000	rate valve stem	21	MBE-179-000	bottom meter block
8	* ORE-VIT-214	O-ring	22	* ORE-VIT-212	O-ring
9	* ORE-VIT-010	O-ring	23	CF	adaptor
10	RVE-344-000	valve bonnet	24	CF	adaptor
11	RVE-343-000	valve knob	25	* CF	gasket
12	BTE-STA-154	10-32 x 3/4 screw	26	* CF	gasket
13	MBE-178-000	top meter block	27	RVE-548-000	nut wire
14	MTE-166-2KO	meter tube assembly 2000ppd	28	RVE-239-000	inlet wrench
	MTE-166-1KO	meter tube assembly 1000ppd	29	* TCE-119-100	3/8 tubing 90
	* parts included in kit# KTE-2000-RMP		30	* 1/4" plug	1/4" plug
	CF	consult factory			

130 West Main Street, PO Box 99, Silverdale, PA 18962 USA
 PHONE: 215-453-2533 FAX: 215-453-1101 EMAIL: sales@enclor.com WEB: www.enclor.com



ENCHLOR^{INC.}

EJECTOR ASSEMBLY - 2000ppd (40 kg/h)
PART# EJE-2000-CL2

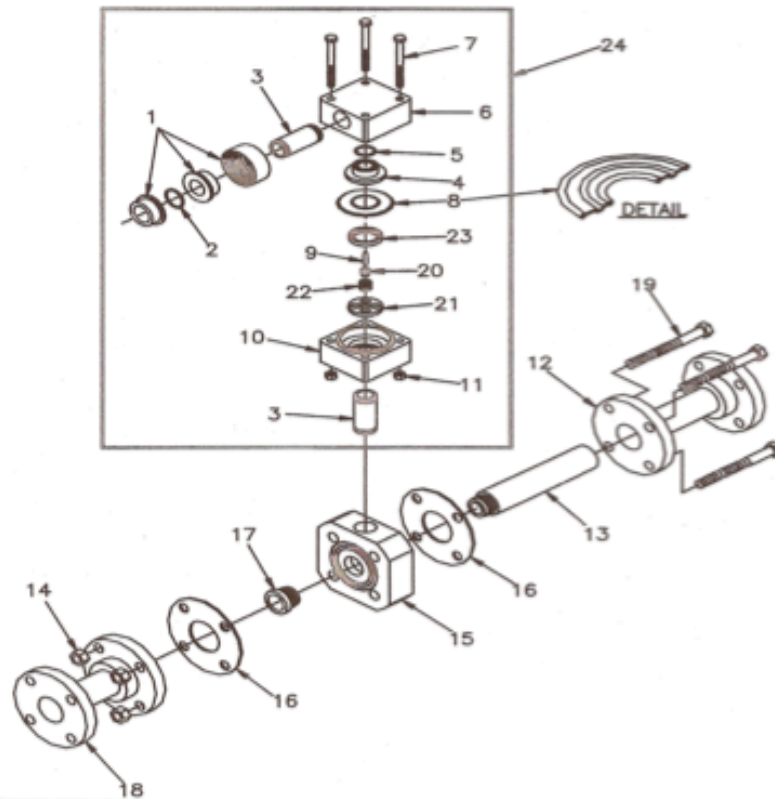

KEY

#	PART#	DESCRIPTION
1	1" union	1" union
2	* ORE-VIT-126	O-ring
3	1" nipple	1" nipple
4	EJE-162-000	diaphragm bolt
5	* ORE-VIT-214	O-ring
6	EJE-168-000	check valve top body
7	BTE-STA-158	3/8-16 x 4" bolt
8	* DIE-116-000	diaphragm
9	EJE-140-000	guide pin
10	EJE-167-000	check valve bottom body
11	NTE-STA-146	3/8-16 nut
12	EJE-890-000	throat housing
* included in spare parts kit #KTE-2000-EJC		

KEY

#	PART#	DESCRIPTION
13	EJE-166-xxx	throat
14	NTE-STA-230	5/8-11 nut
15	EJE-169-000	ejector body
16	* GAE-VIT-308	gasket
17	EJE-165-xxx	nozzle
18	EJE-891-000	nozzle housing
19	BTE-STA-156	5/8-11 x 4 1/2" bolt
20	EJE-151-000	pin guide
21	EJE-164-000	spring retainer
22	SPE-110-000	spring
23	EJE-163-000	diaphragm nut
24	EJE-3499	check valve assembly

130 West Main Street, PO Box 99, Silverdale, PA 18962 USA
 PHONE: 215-453-2533 FAX: 215-453-1101 EMAIL: sales@enchlor.com WEB: www.enchlor.com

NOZZLE SIZING CHART for 2000 PPD (40 kg/hr)

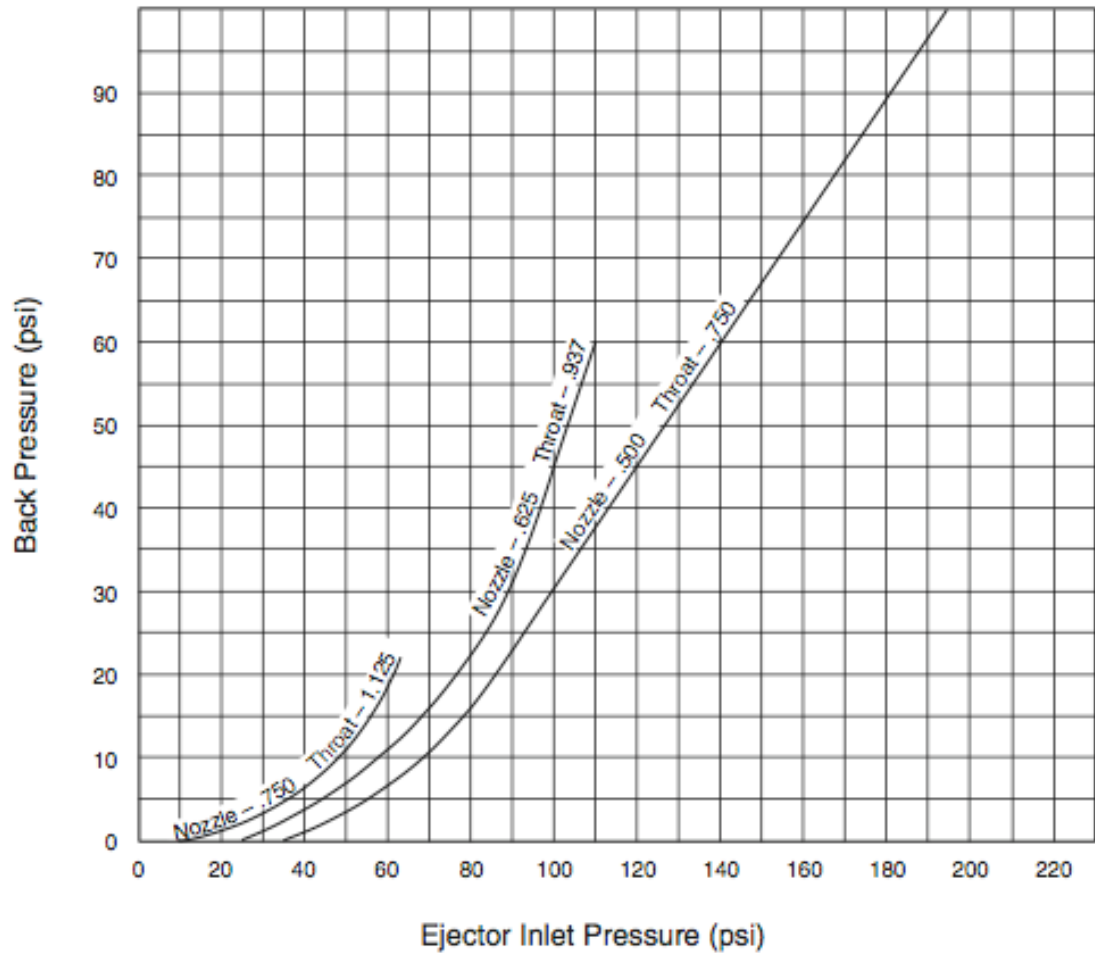



NOZZLE SIZING CHART (EJH-2000-CL2) for 3000 PPD (60 kg/hr)

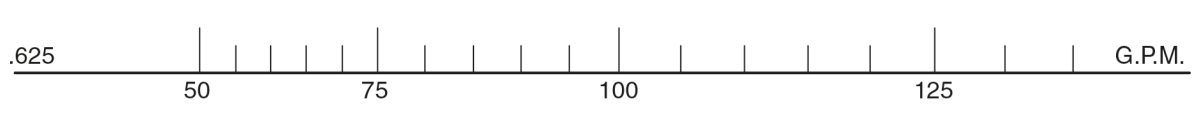
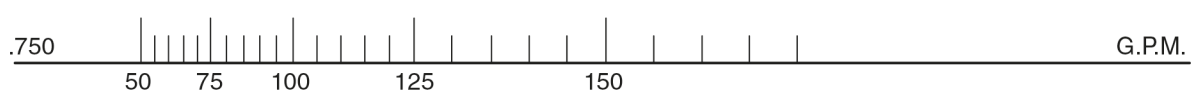
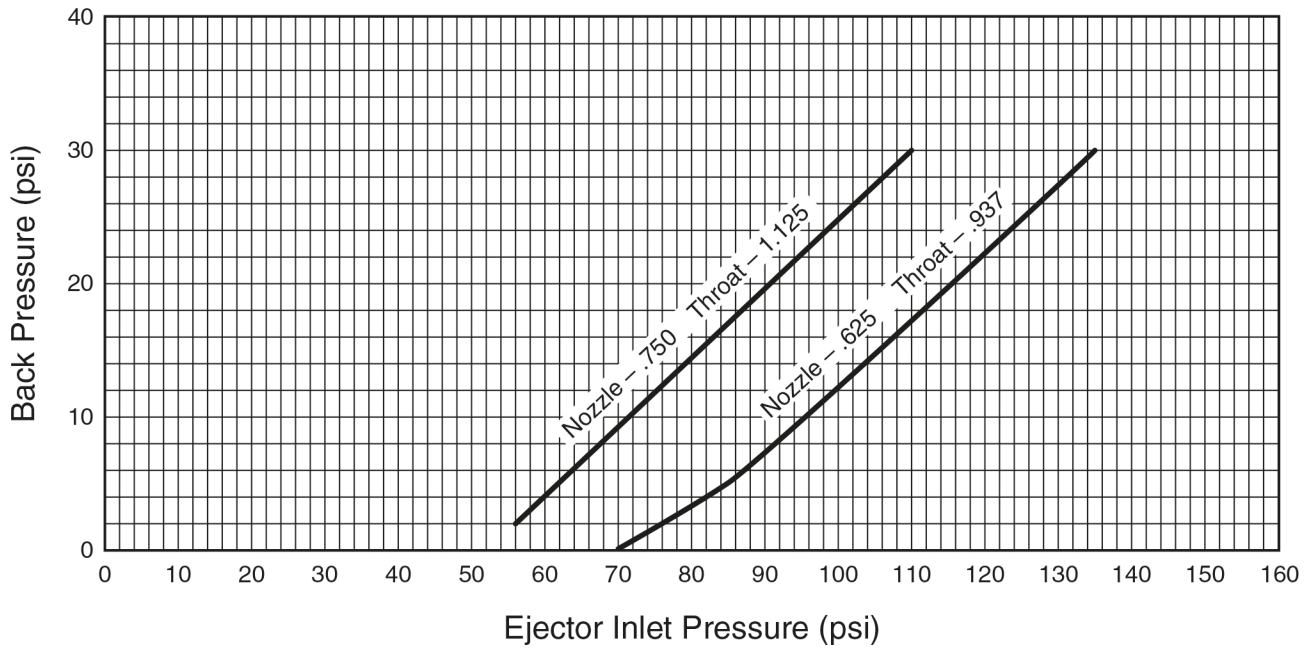

Note: Pressure combinations that plot below the line for any given nozzle are acceptable for operating that nozzle at the stated chemical feed rate for that chart. Pressure combinations that fall above the line for any given nozzle are not acceptable.



Series E2100 WALL PANEL MOUNTED HIGH CAPACITY GAS FEEDER SYSTEMS

STANDARD SYSTEM

Description	Model	Capacity
Each system includes		
One (1) VRE-2000-CL2 vacuum regulator	E2104C2	0-1000ppd(20Kg/h)
One (1) MPE-2000-CL2 meter panel	E2105C2	0-2000ppd(40Kg/h)
One(1) EJE-2000-CL2 ejector assembly		
one(1) accessory pack		

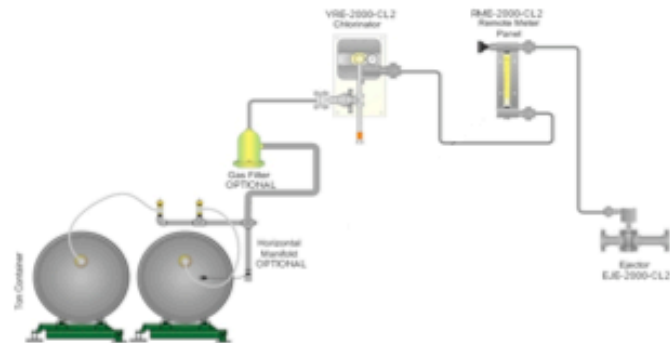

SWITCHOVER SYSTEM

Description	Model	Capacity
Each system includes		
Two (2) VRE-2000-CL2 vacuum regulator	E2104C5	0-1000ppd(20Kg/h)
One (1) SOE-2000-CL2 switchover module	E2105C5	0-2000ppd(40Kg/h)
One (1) MPE-2000-CL2 meter panel		
One(1) EJE-2000-CL2 ejector assembly		
one(1) accessory pack		

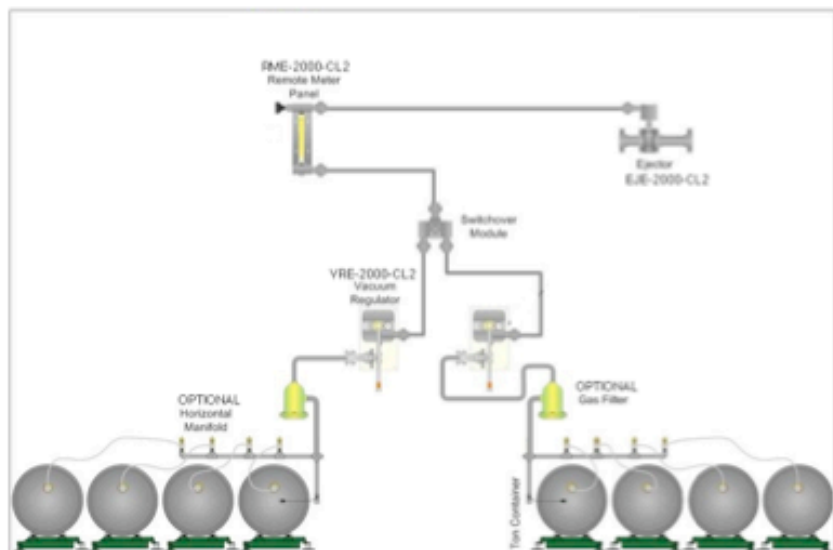

Series E2100 MANIFOLD MOUNTED HIGH CAPACITY GAS FEEDER SYSTEMS

STANDARD SYSTEM

Description	Model	Capacity
Each system includes		
One (1) VRE-2100-CL2 vacuum regulator	E2104C1	0-1000ppd(20Kg/h)
One (1) MPE-2000-CL2 meter panel	E2105C1	0-2000ppd(40Kg/h)
One(1) EJE-2100-CL2 ejector assembly		
one(1) accessory pack		

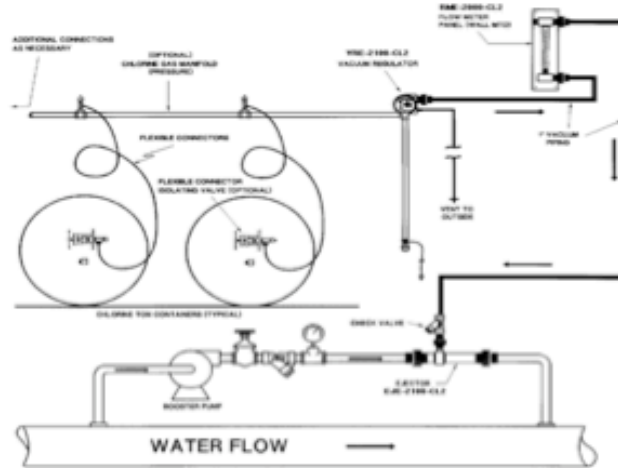

SWITCHOVER SYSTEM

Description	Model	Capacity
Each system includes		
Two (2) VRE-2100-CL2 vacuum regulator with internal switchover	E2104C4	0-1000ppd(20Kg/h)
One (1) MPE-2000-CL2 meter panel	E2105C4	0-2000ppd(40Kg/h)
One(1) EJE-2100-CL2 ejector assembly		
one(1) accessory pack		

